



Certified to NSF/ANSI 61

Basket Strainers

91 Series

Offset, Flat Bottom Design

Offset, Domed Bottom Design

- Carbon or Stainless Steel
- Flanged or Butt Weld
- Sizes from 2" to 36"

ASME Code ("U" or "UM") and non-code design fabricated basket strainers



SUITABLE USES



Air & Gas



Desalination



Coolant



Water



Electronics



Coatings



Oil & Gas



Chemical



Pulp & Paper



Power



Marine



Equipment

RATINGS

- ASME Class 150
- ASME Class 300
- ASME Class 600
- ASME Class 900
- ASME Class 1500
- ASME Class 2500

DESIGN PRESSURE

Up to 3700 @ 800° F (427° C)

AVAILABLE MATERIALS

Carbon or Stainless Steel 304 or 316, LDX2101, C276, AL6XN, 2205, 2507 & Monel 400, Titanium and other materials.

**Stainless steel 304 and 316 are NSF/ANSI 61 certified*

ADDITIONAL FEATURES

Swing bolt or thru-bolt closures available
Domed bottom and flat bottom configurations

Basket Strainers

91 Series | Fabricated Basket Strainers

- Carbon or Stainless Steel
- Flanged or Butt Weld
- Sizes from 2" to 36"



STRAINER SPECIFICATIONS

Configuration 91A - Offset, flat bottom w/ swing bolt closure
 91B - Offset, flat bottom w/ thru bolt closure
 91C - Offset, domed bottom w/ swing bolt closure
 91D - Offset, domed bottom w/ thru bolt closure

Cover Flat cover for 10" and smaller
 Domed cover for 12" and larger
Cover lifting lug standard on all strainers 10' and larger

Basket Options Single basket (std)
Multi-basket configuration available based on sizing

Inlet/Outlet 2" TO 36"
Larger sizes available, contact Fil-Trek

Vent 1/2"*

Certifications U, UM, CE, NB, CRN, CE

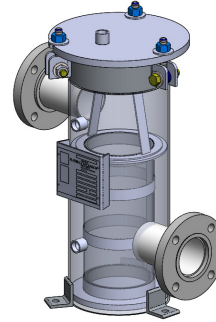

91A Series

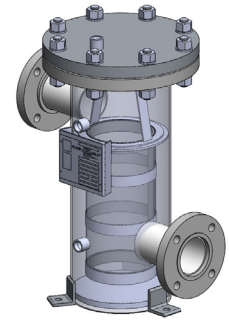

91B Series

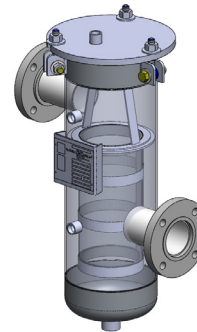

91C Series

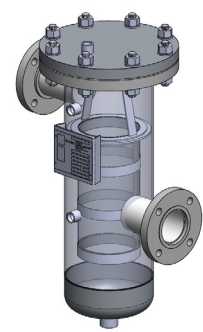

91D Series

PRESSURE & TEMPERATURE DESIGNATION

DESIGNATION	MOC	PSI	TEMP (°F)	ANSI RATING	DESIGNATION	MOC	PSI	TEMP (°F)	ANSI RATING
PT1	CS	285	100	ANSI 150	PT7	CS	2215	100	ANSI 900
	SS304/SS316	270				SS304/SS316	2155		
PT2	CS	200	400	ANSI 150	PT8	CS	1900	400	ANSI 900
	SS304/SS316	190				SS304/SS316	1490		
PT3	CS	740	100	ANSI 300	PT9	CS	3700	100	ANSI 1500
	SS304/SS316	720				SS304/SS316	3595		
PT4	CS	635	400	ANSI 300	PT10	CS	3170	400	ANSI 1500
	SS304/SS316	495				SS304/SS316	2485		
PT5	CS	1480	100	ANSI 600	PT11	CS	6150	100	ANSI 2500
	SS304/SS316	1440				SS304/SS316	5995		
PT6	CS	1270	400	ANSI 600	PT12	CS	5200	400	ANSI 2500
	SS304/SS316	995				SS304/SS316	4140		

*Table above based on ANSI flange ratings. Fil-Trek will design based on application pressure and temperature requirements.

**Max temperature may be limited to gasket material.

Basket Strainers

91 Series | Fabricated Basket Strainers

- Carbon or Stainless Steel
- Flanged or Butt Weld
- Sizes from 2" to 36"



STRAINER OPTIONS

*Indicates standard configuration

Series /Style	91A - Offset, flat bottom w/ Swing-bolt closure
Configuration	91B - Offset, flat bottom w/ ANSI thru-bolt closure
Options	91C - Offset, domed bottom w/ swing bolt closure 91D - Offset, domed bottom w/ thru bolt closure

Connection Options**	F – Raised Face Flange* Other Available Options: BW – Butt Weld (Sch 10 to 160) Flat Face Flange Ring Joint Flange Grooved Socket Weld NPT Threaded Wafer Flat Face (Smooth Finish) Wafer Flat Face (Serrated Finish) Wafer Ring Joint <i>**Based on standard of construction</i>
-----------------------------	--

Finish Options	(-) External paint "National Blue" (std for carbon steel housings)* (-) Bead Blast (std for stainless steel 304 and 316)* EP1 – Electro polish Inside/Outside EP2 – Inside only EP3 – Outside only PP – Passivation
-----------------------	--

Leg Options	Leg tabs* (std for flat bottom) No legs* (std for domed bottom) Other Available Options: Angle Iron Legs, Skirt
--------------------	--

Basket/Mesh Options	PERF OPTIONS	MESH OPTIONS
1/8" *	10	10
<i>(See Screen Openings chart for more options)</i>	3/16"	20
	1/4"	30
	3/8"	40
	1/2"	50
	5/8"	60
	3/4"	80
	7/8"	100
	1"	120

Cover Options**	Predetermined by Series Number* Other Available Options: Bolted Cover (Gasket Seal) w/ Davit Yoke Cover (O-Ring Seal) Quick Opening Threaded Cover (O-Ring Seal) Quick Opening C-Clamp Cover (O-Ring Seal) Grooved <i>**Based on standard of construction</i>
------------------------	--

O-Ring/Gasket Options	For 91A/91C BN - Buna-N* EP - EPDM VI - Viton SI - Silicone TEV – Teflon encap. Viton For 91B/91D Spiral Wound Flexitallic* Garlon Vegetable Fibre <i>Other materials available, contact factory</i>
------------------------------	---

PRODUCT NOMENCLATURE

S4	91A	10	6	F	PT2	-
MOC	MODEL	BODY DIAMETER	INLET/OUTLET	CONNECTION	PRESSURE CLASS	ADDITIONAL OPTIONS
(-) CARBON STEEL S4 - SS304 S6 - SS316	91A 91B 91C 91D	See tables on preceding pages for body diameter	See tables on preceding pages for inlet/outlet sizing	F - Raised Face Flange See "Strainer Options" above for other options	See Pressure & Temperature Designation table	See "Strainer Options" above for: Finish options Basket Perf/Mesh options O-Ring/Gasket options Cover/Headlift Options Leg options

Basket Strainers

91 Series | Fabricated Basket Strainers

- Carbon or Stainless Steel
- Flanged or Butt Weld
- Sizes from 2" to 36"



MODEL DIMENSIONAL DETAILS

91A/91C Series (Offset w/ Swing Bolt) | 150#, 300#

INLET/ OUTLET	BODY DIA.	150#					300#				
		A	B	C	D	E	A	B	C	D	E
2"	6"	6.625"	14"	6"	12"	21"	Contact Fil-Trek for dimensional information				
3"	8"	8.625"	17"	6"	16"	23"					
4"	8"	8.625"	17"	6"	18"	23"					
5"	10"	10.75"	20"	6"	20"	31"					
6"	10"	10.75"	20"	6"	20"	31"					
8"	12"	12.5"	25"	11"	26"	35"					
10"	16"	16.5"	29"	11"	30"	41"					
12"	18"	18.5"	31"	14"	32"	44"					
14"	20"	20.5"	36"	16"	36"	51"					
16"	24"	24.5"	36"	16"	40"	53"					
18"	24"	24.5"	38"	16"	40"	55"					
20"	30"	30.5"	47"	18"	48"	65"					
24"	36"	36.625"	55"	20"	56"	78"					

Available in sizes larger than 24" please contact Fil-Trek. Specifications listed above are for reference only. All quotes are complete with certified drawing which indicate accurate dimensions and weight.

CHART LEGEND

- A** Body Diameter
- B** Inlet to Floor
- C** Outlet to Floor
- D** Face to Face
- E** Floor to Cover

91A Series

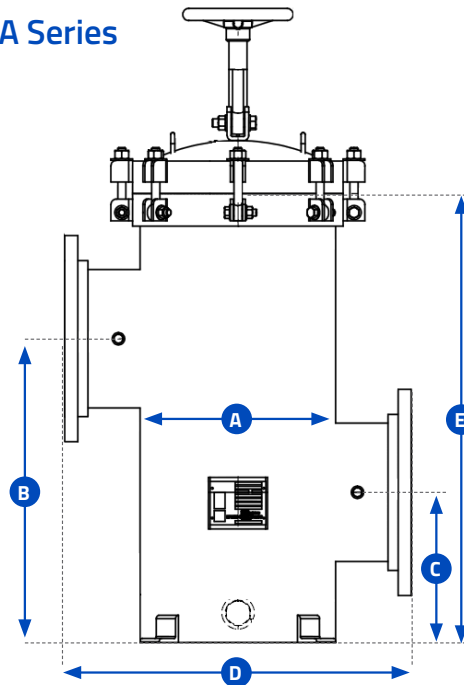

91C Series

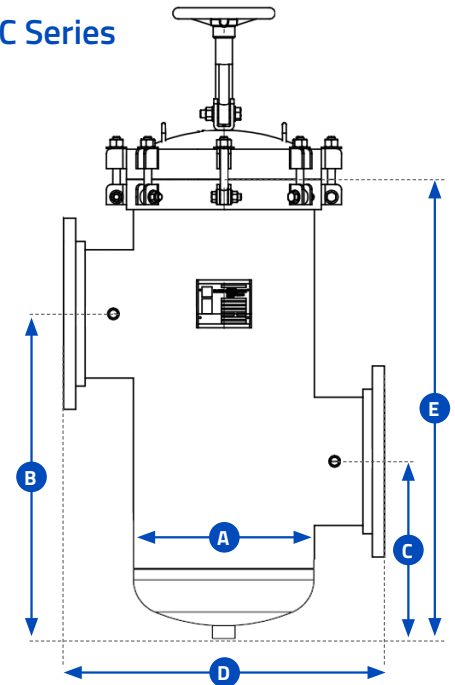

Basket Strainers

91 Series | Fabricated Basket Strainers

- Carbon or Stainless Steel
- Flanged or Butt Weld
- Sizes from 2" to 36"



MODEL DIMENSIONAL DETAILS (CONTINUED...)

91A/91C Series (Offset w/ Swing Bolt) | 600#, 900#

INLET/ OUTLET	BODY DIA.	600#					900#				
		A	B	C	D	E	A	B	C	D	E
2"	6"	Contact Fil-Trek for dimensional information Limited sizing, contact Fil-Trek for availability									
3"	8"										
4"	8"										
5"	10"										
6"	10"										
8"	12"										
10"	16"										
12"	18"										
14"	20"										
16"	24"										
18"	24"										
20"	30"										
24"	36"										

Available in sizes larger than 24" please contact Fil-Trek. Specifications listed above are for reference only. All quotes are complete with certified drawing which indicate accurate dimensions and weight.

CHART LEGEND

- A** Body Diameter
- B** Inlet to Floor
- C** Outlet to Floor
- D** Face to Face
- E** Floor to Cover

91A Series

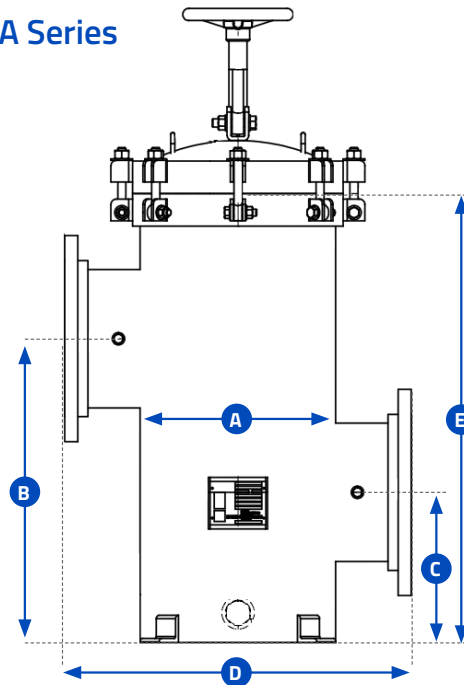

91C Series

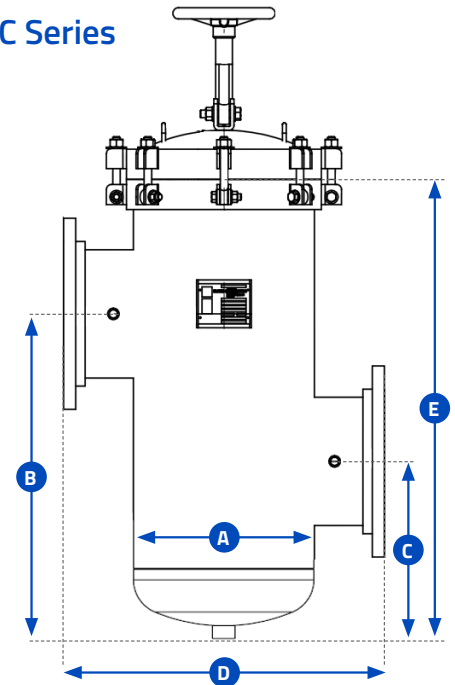

Basket Strainers

91 Series | Fabricated Basket Strainers

- Carbon or Stainless Steel
- Flanged or Butt Weld
- Sizes from 2" to 36"



MODEL DIMENSIONAL DETAILS

91B/91D Series (Offset w/ Thru Bolt) | 150#, 300#

INLET/ OUTLET	BODY DIA.	150#					300#				
		A	B	C	D	E	A	B	C	D	E
2"	6"	Contact Fil-Trek for dimensional information									
3"	8"										
4"	8"										
5"	10"										
6"	10"										
8"	12"										
10"	16"										
12"	18"										
14"	20"										
16"	24"										
18"	24"										
20"	30"										
24"	36"										

Available in sizes larger than 24" please contact Fil-Trek. Specifications listed above are for reference only. All quotes are complete with certified drawing which indicate accurate dimensions and weight.

CHART LEGEND

- A** Body Diameter
- B** Inlet to Floor
- C** Outlet to Floor
- D** Face to Face
- E** Floor to Cover

91B Series

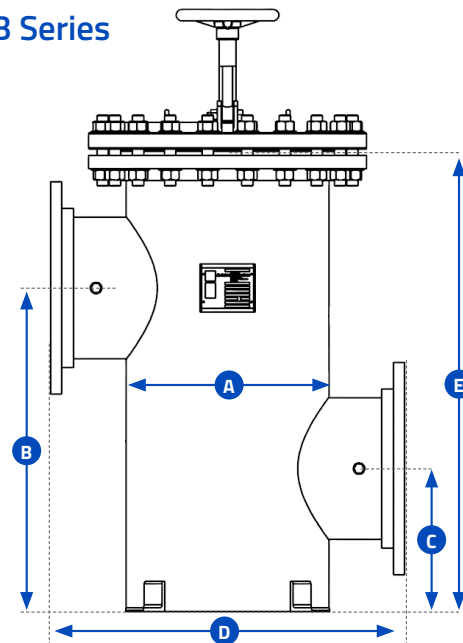

91D Series

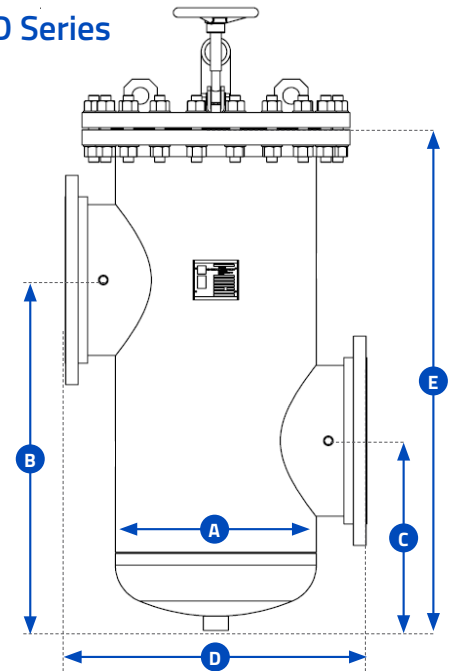

Basket Strainers

91 Series | Fabricated Basket Strainers

- Carbon or Stainless Steel
- Flanged or Butt Weld
- Sizes from 2" to 36"



MODEL DIMENSIONAL DETAILS (CONTINUED...)

91B/91D Series (Offset w/ Thru Bolt) | 600#, 900#

INLET/ OUTLET	BODY DIA.	600#					900#				
		A	B	C	D	E	A	B	C	D	E
2"	6"	Contact Fil-Trek for dimensional information									
3"	8"										
4"	8"										
5"	10"										
6"	10"										
8"	12"										
10"	16"										
12"	18"										
14"	20"										
16"	24"										
18"	24"										
20"	30"										
24"	36"										

91B/91D Series (Offset w/ Thru Bolt) | 1500#, 2500#

INLET/ OUTLET	BODY DIA.	1500#					2500#				
		A	B	C	D	E	A	B	C	D	E
2"	6"	Contact Fil-Trek for dimensional information									
3"	8"										
4"	8"										
5"	10"										
6"	10"										
8"	12"										
10"	16"										
12"	18"										
14"	20"										
16"	24"										
18"	24"										
20"	30"										
24"	36"										

Available in sizes larger than 24". Specifications listed above are for reference only. All quotes are complete with certified drawing which indicate accurate dimensions and weight.

Basket Strainers

91 Series | Fabricated Basket Strainers

- Carbon or Stainless Steel
- Flanged or Butt Weld
- Sizes from 2" to 36"



BASKET OPTIONS

We can manufacture replacement and custom basket designs for basket strainers, T strainers, Y strainers, duplex strainers and more.

Single & Multi Basket Design

Single baskets or multi basket design options are primarily based on size of strainer. A large strainer using a single basket can make it difficult to remove and maintain due to its weight. Multiple baskets can make removal much easier especially if overhead cranes or lifts are unavailable.

Custom Basket Design

We can customize our basket design to meet a variety of non-standard requirements. Angled or flat, alternate bottom designs etc.

Material of Construction

We can make strainer baskets in a variety of materials to meet a variety of requirements. Below is an outline of what materials we are capable of using;

- Carbon steel
- SS304 or SS316
- C 276
- AL6XN
- LDX2101
- 2205
- 2507
- Monel 400
- Titanium

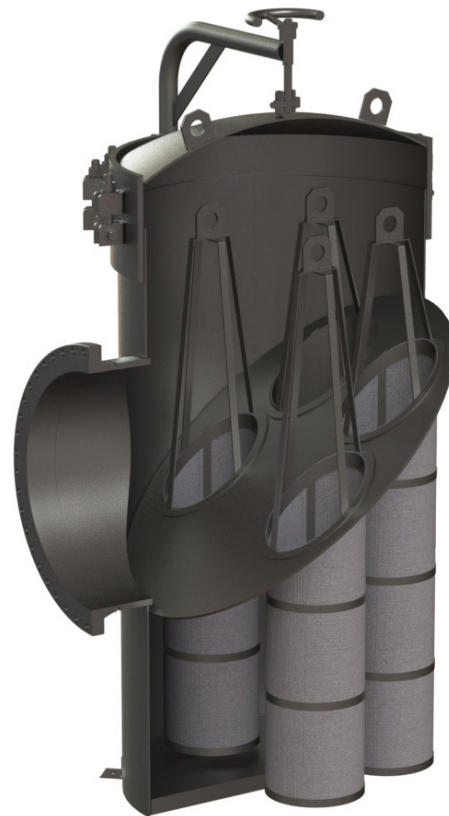
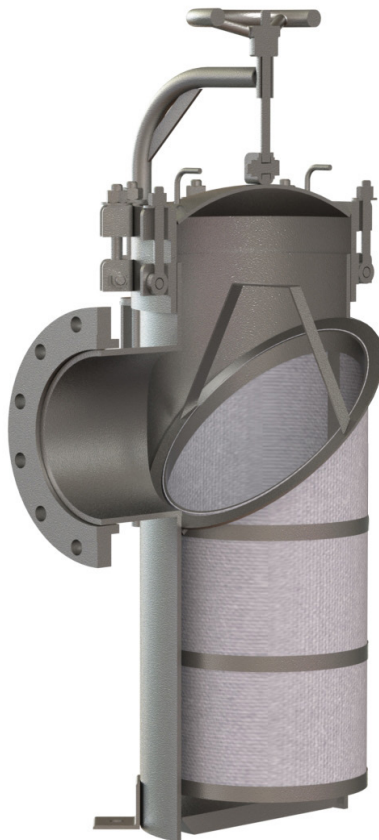

Basket Strainers

91 Series | Fabricated Basket Strainers

- Carbon or Stainless Steel
- Flanged or Butt Weld
- Sizes from 2" to 36"



CLOSURE AND QUICK OPENING COVER OPTIONS

Fil-Trek designs and fabricates a variety of closure and quick opening cover options to accommodate strict applications and requirements. All materials of construction are in accordance with ASME specifications and manufacturing complies with the applicable rules of the ASME Code for Pressure Piping and with the ASME Boiler and Pressure Vessel Code.

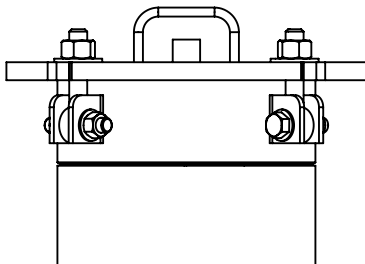

The most economical quick opening closure offered for fabricated strainers with nominal pressure applications. The swing bolt hinged cover uses an O-ring to seal. Easy to open by quickly and easily by loosening the swing bolts until they clear the holding lugs and swinging the head open on its hinge.

MECHANICAL DAVIT ASSEMBLY

Our mechanical davit assembly makes it easy for the operator to open and swing the cover away to facilitate basket or screen removal for cleaning. It is used primarily for larger strainers where cover removal is difficult and heavy. This is the most inexpensive alternative to quick release covers, especially when operating conditions require a bolted cover. Available for swing bolt and ANSI closures.

**Hydraulic davit head lift also available.

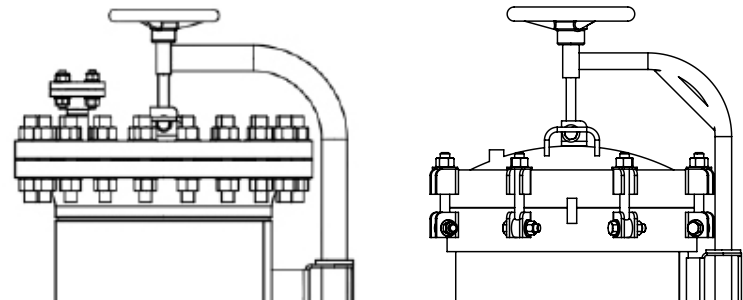

Basket Strainers

91 Series | Fabricated Basket Strainers

- Carbon or Stainless Steel
- Flanged or Butt Weld
- Sizes from 2" to 36"



THREADED HINGED COVER

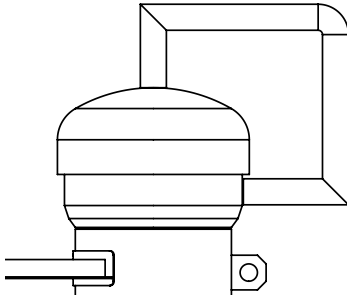

The quick open threaded hinged closure uses a cap fastened to a hub and is welded to the strainer body. The female cap is threaded onto the male hub using O-rings to seal. The O-ring prevents corrosion of the closure threads and provides a long, trouble free service. The threaded cover can be used for both nominal and high pressure applications. Available in both vertical and horizontal configurations.

YOKE CLOSURE

The Yoke hinged cover is a true ANSI rated closure and uses an O-ring seal. Used primarily on high pressure applications, it is available for 150#, 300#, 600#, 900# and 1500# ANSI ratings with a wide range of operating aids, ranging from a single lever chain and sprocket drive to completely automated.

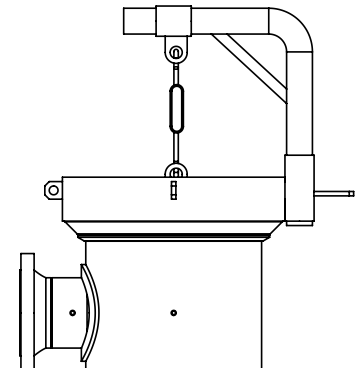

CLOSURE COMPARISON

	COVER TYPE			
	HINGED COVER	MECHANICAL DAVIT	THREADED COVER	YOKE CLOSURE
COST	Low	Moderate	High	High
QUICK OPENING ABILITY	Good	Fair	Best	Best
LOW PRESSURE APPLICATIONS	X	X	-	-
NOMINAL PRESSURE APPLICATIONS	X	X	X	X
HIGH PRESSURE APPLICATIONS	-	X	X	X

Basket Strainers

91 Series | Fabricated Basket Strainers

- Carbon or Stainless Steel
- Flanged or Butt Weld
- Sizes from 2" to 36"



STRAINER APPLICATION WORKSHEET

Please use the following worksheet to enter as much detail as possible about the strainer application you are sizing for. The minimum requirement we need to help size will be the areas marked with an '*':

Operating Conditions

Name of Gas* _____

Max. Operating Flow Rate* _____

Gas Specific Gravity (Air = 1)* _____

Type of System or Location in Process* _____

Min. Operating Pressure (PSIG)* _____

Min. Operating Temperature (F) _____

Amount of Liquids Present (GPD) _____

Amount of Particulate Present (Parts per 100 scf) _____

Max. Allowable Clean Pressure Drop _____

Name of Liquid Present _____

@ _____ Pressure (PSIG)

OR Mole Weight/Composition _____

Dry? Wet?

Max. Operating Pressure (PSIG) _____

Max. Operating Temperature (F)* _____

Specific Gravity (Water = 1) _____

Name of Particulate _____

(Standard = 2 PSID Flange to Flange)

Mechanical Data

Design Pressure Min.* _____ Max.* _____

ASME Code Required?* _____

If YES, Pressure (PSI) _____ Temp (F) _____

Fire Safe Service _____

Inlet/Outlet Type Flanged Threaded

Type/ANSI Rating of Flanges (#) _____

Vessel MOC CS SS304 SS316

Internals MOC CS SS304 SS316

Design Temperature Min.* _____ Max.* _____

Sour Service? Acid Service?

Corrosion Allowance (in) _____

(ie All Connections/Closures Flanged?) _____

Other (Please specify) _____

Face RF RTJ Type SO WN LWN

Other (Please specify) _____

Other (Please specify) _____

Other Details

Basket Strainers

91 Series | Fabricated Basket Strainers

- Carbon or Stainless Steel
- Flanged or Butt Weld
- Sizes from 2" to 36"



SCREEN/BASKET DESIGN CHECKLIST

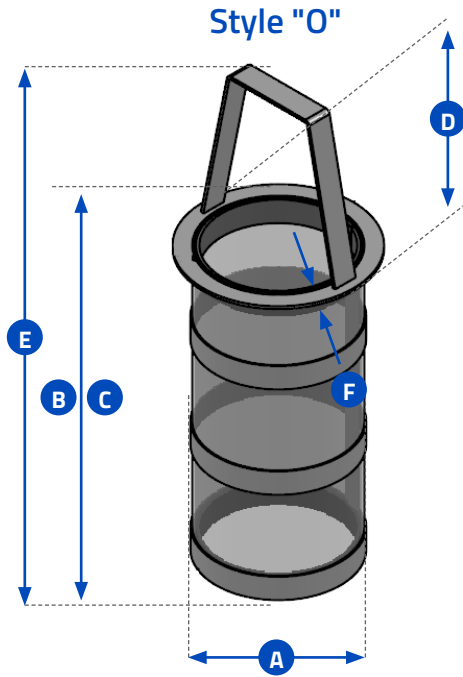

Performance Requirements

Req. Level of Filtration _____

Material of Construction _____

Min. Specified Burst Pressure _____

Flow Direction _____

Dimensional Requirements

Design Style (O or I)

A Basket Outside Diameter _____

B Basket Height - *Shortest* _____

C Basket Height - *Longest* _____

D Ring Outside Diameter _____

E Overall Height _____

F Ring Thickness _____

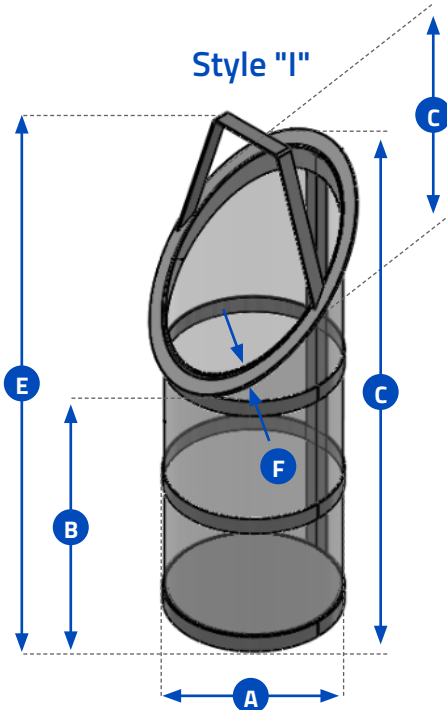

Additional Notes

Basket Strainers

91 Series | Fabricated Basket Strainers

- Carbon or Stainless Steel
- Flanged or Butt Weld
- Sizes from 2" to 36"



SCREEN OPENINGS

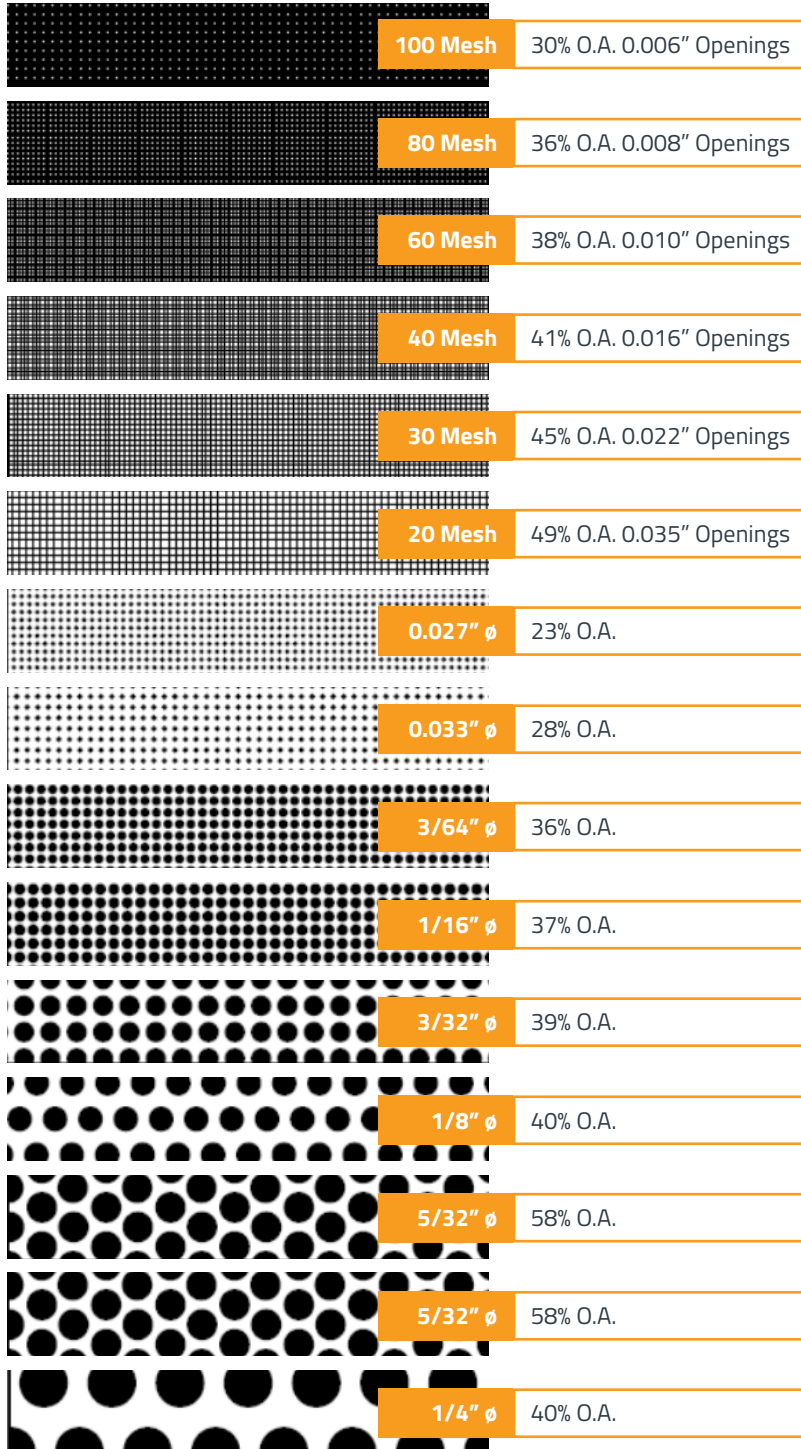

FACTORS TO CONSIDER

1 Purpose

If the strainer is being used for protection rather than direct filtration, standard screens will suffice in most applications.

2 Service

With services that require extremely sturdy screens, such as high pressure/temperature applications or services with high viscosities, perforated screens without mesh liners are recommended. If a mesh liner is required to obtain a certain level of filtration, then a trapped perf/mesh/perf combination is recommended.

3 Filtration Level

When choosing a perf. or a mesh/perf. combination, attention should be given to ensure overstraining does not occur. As a general rule, the specified level of filtration should be no smaller than half the size of the particle to be removed. If too fine a filtration is specified, the pressure drop through the strainer will increase very rapidly, possibly causing damage to the screen.

Screen openings other than those shown above are readily available. Various mesh sizes as fine as 5 micron and perforated plate as coarse as 1/2" Dia. are in inventory.

Screens are available in a wide range of materials. Screens of carbon steel, stainless steel (304, 316), alloy 20, monel 400, hastelloy C and titanium grade 2 are in inventory.

Custom manufactured screens are available upon request. Please consult factory.

Basket Strainers

91 Series | Fabricated Basket Strainers

- Carbon or Stainless Steel
- Flanged or Butt Weld
- Sizes from 2" to 36"



PRESSURE DROP | LIQUIDS

Fabricated Basket Strainers | 2" to 24"

Figure 1

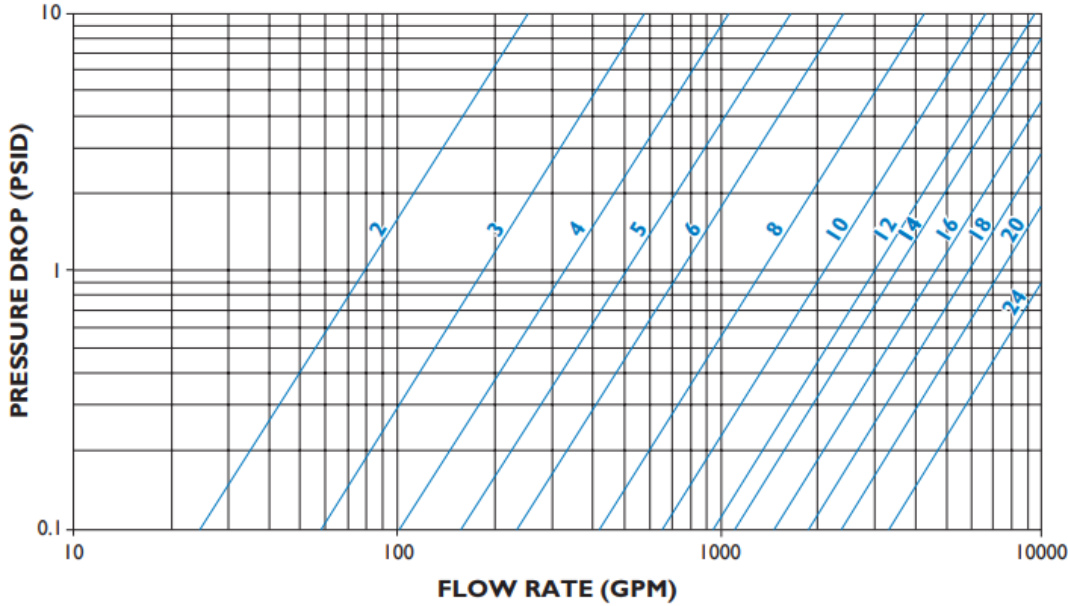

Fabricated Duplex Basket Strainers | 5" to 24"

Figure 2

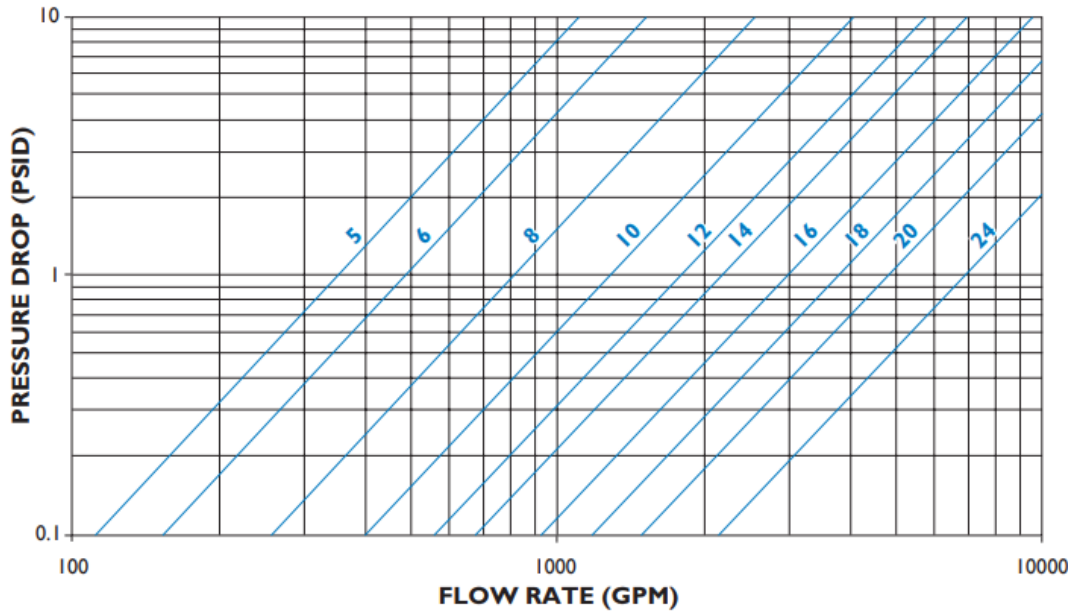

Notes:

Pressure drop curves are based on water flow with standard screens.

See Chart # 1 for correction factors to be used with other fluids and/or screen openings.

Basket Strainers

91 Series | Fabricated Basket Strainers

- Carbon or Stainless Steel
- Flanged or Butt Weld
- Sizes from 2" to 36"



PRESSURE DROP | LIQUIDS

Fabricated T Strainers | 2" to 24"

Figure 3

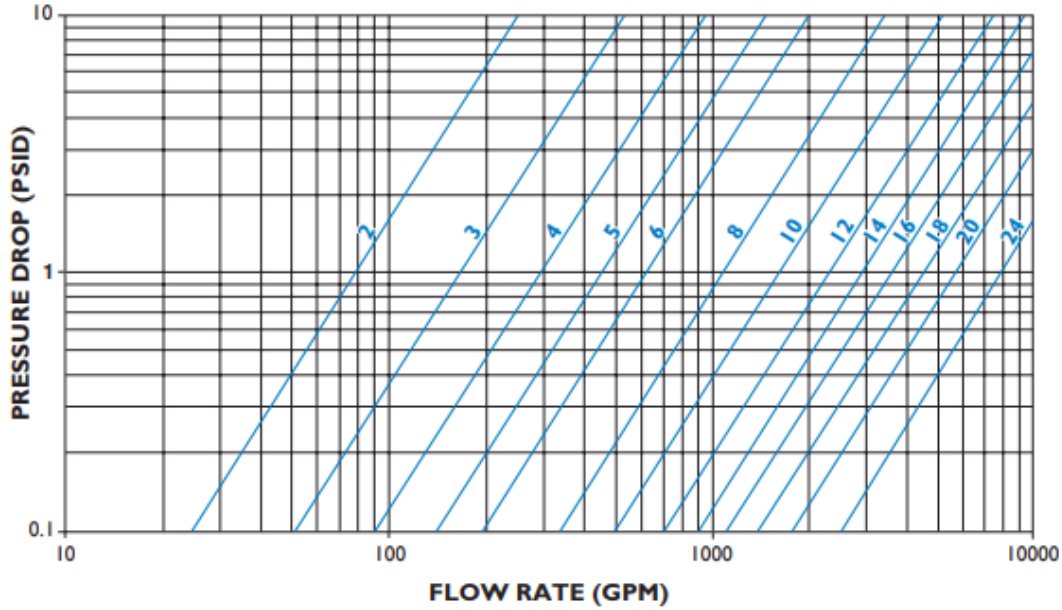

Fabricated Y Strainers | 2" to 24"

Figure 4

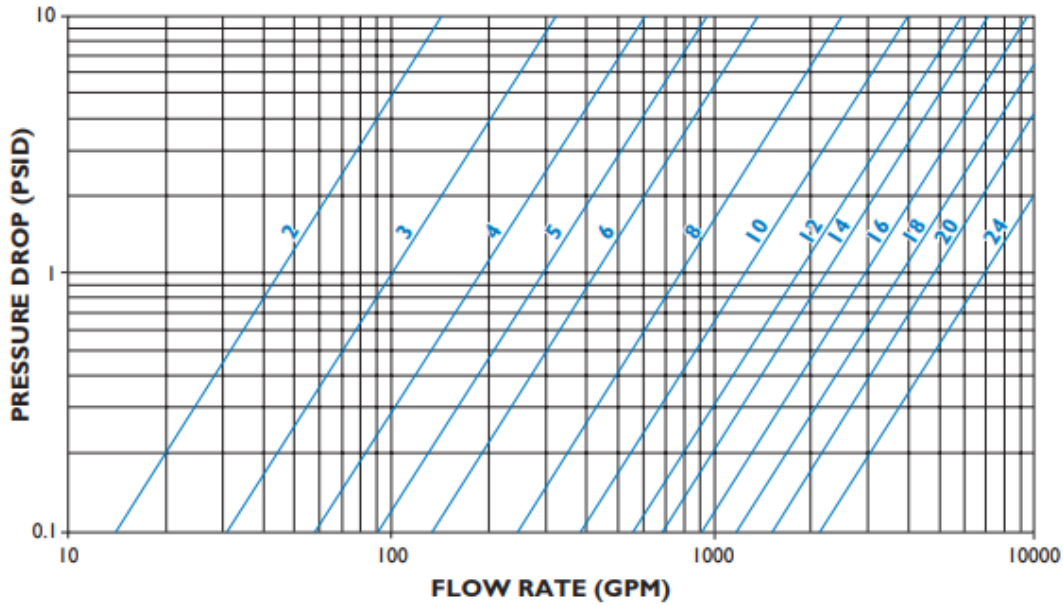

Notes:

Pressure drop curves are based on water flow with standard screens.

See Chart # 1 for correction factors to be used with other fluids and/or screen openings.

Basket Strainers

91 Series | Fabricated Basket Strainers

- Carbon or Stainless Steel
- Flanged or Butt Weld
- Sizes from 2" to 36"



PRESSURE DROP | LIQUIDS

Temporary Strainers | 3/4" to 5"

Figure 5

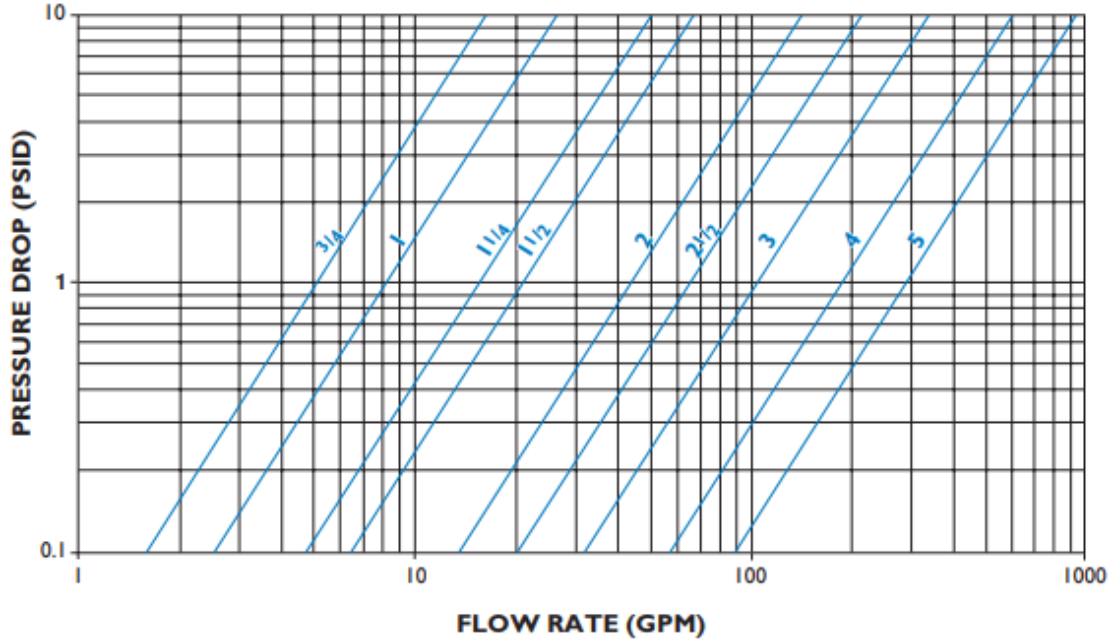

Temporary Strainers | 6" to 48"

Figure 6

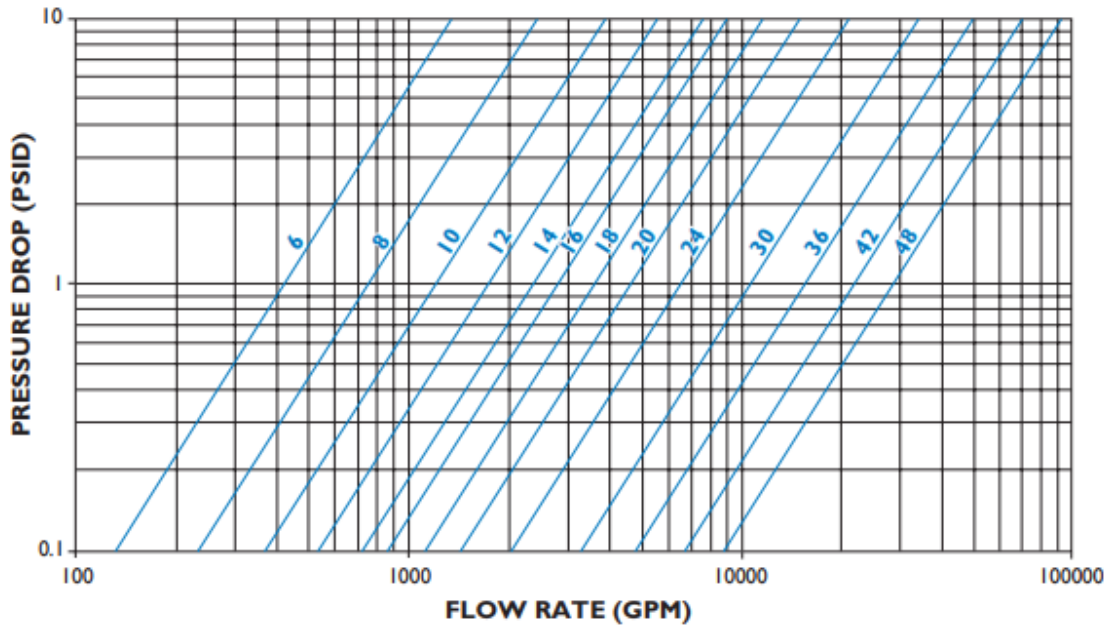

Notes:

Pressure drop curves are based on water flow with standard screens.

See Chart # 1 for correction factors to be used with other fluids and/or screen openings.

Basket Strainers

91 Series | Fabricated Basket Strainers

- Carbon or Stainless Steel
- Flanged or Butt Weld
- Sizes from 2" to 36"



SCREEN CORRECTION FACTOR CHART

Non-Standard and Mesh Lined Screens

Chart # 1

SIZE RANGE	PERF. PLATE % SCREEN MATERIAL OPEN AREA					MESH LINED SCREENS % SCREEN MATERIAL OPENING AREA		
	60%	50%	40%	30%	20%	50%	40%	30%
1/4" to 1 1/2"	0.45	0.55	0.70	1.00	1.15	1.05	1.05	1.20
2" to 48"	0.65	0.80	1.00	1.40	2.15	1.05	1.05	1.20

BASKET STRAINER EXAMPLE

Strainer Size: 10"
Screen Size: 100 Mesh, 1/8" Perf
Flow Rate: 3000 GPM
Service: Water
Specific Gravity: 1
Viscosity: 100 cP

How To Calculate:

- Use Figure 1 to get the pressure drop of the screen.
- Refer to the Screen Opening chart to determine the % Open Area of the mesh/screen size being used.
- Using the chart above, find the correction factor to be used.
- Multiply the PSID by the correction factor to determine the total pressure drop.

Example:

RESULTS
2.0
30%
1.20
2.4
2.0 x 1.2 = 2.4 PSID clean

VISCOSITY & DENSITY CORRECTION FACTOR CHART

Chart # 2

SIZE RANGE	COMPONENT FACTOR (CF)
3/4" to 1 1/2"	0.25
2" to 48"	0.35

Chart # 3

VISCOSITY (cP)	BODY LOSS FACTOR (BF)	SCREEN LOSS FACTOR			
		PERF ONLY (PF)	20 MESH (MF)	30 to 40 MESH (MF)	60 to 300 MESH (MF)
10	1.0	1.15	1.20	1.40	1.50
25	1.2	1.25	2.00	2.20	2.50
100	1.6	1.40	3.00	4.00	6.50
200	2.2	1.50	4.50	7.00	11.50
500	4.4	1.60	10.00	15.00	25.00
1000	8.0	1.70	15.00	30.00	50.00
2000	15.0	1.90	30.00	60.00	100.00

How To Calculate:

- Use the pressure drop (P1) through the strainer with water flow and standard or mesh screens from Chart # 1.
- Multiply P1 by the specific gravity of the fluid actually flowing through the strainer to get P2.
- Using Chart # 2 above, multiply P2 by the correct component factor to get P3.
- Subtract P3 from P2 to equal P4.
- Multiply P3 by the appropriate Body Loss factor from Chart # 3 above to get P5.
- Multiply P4 by the appropriate Screen Loss factor from Chart # 3 above to get P6.
- Total pressure drop will be P5 + P6 = P7.

RESULTS
2.4
2.4
0.84
1.56
1.34
10.14
Total Pressure Drop = 11.48 PSID clean

Basket Strainers

91 Series | Fabricated Basket Strainers

- Carbon or Stainless Steel
- Flanged or Butt Weld
- Sizes from 2" to 36"



CORRECTION FACTORS

For Clogged Screens

Chart # 4

% CLOGGED	RATIO OF FREE SCREEN AREA TO PIPE AREA						
	10:1	8:1	6:1	4:1	3:1	2:1	1:1
10%	-	-	-	-	-	-	3.15
20%	-	-	-	-	-	1.15	3.90
30%	-	-	-	-	-	1.40	5.00
40%	-	-	-	-	-	1.80	6.65
50%	-	-	-	-	1.25	2.50	9.45
60%	-	-	-	1.15	1.80	3.70	14.50
70%	-	-	-	1.75	2.95	6.4	26.00
80%	-	1.10	1.75	3.60	6.25	14.00	58.00
90%	2.30	3.45	6.00	13.50	24.00	55.00	-

NOTES:

- See Figures 7 to 10 for the ratio of free area to pipe area for Fil-Trek strainers equipped with standard screens.
- For screens other than Fil-Trek standard, use the following formula to calculate the ratio free area to pipe area:

$$R = \frac{Ag \times OA}{100Ap}$$

where;

- R** = Ratio free area to pipe area
- Ag** = Gross screen area, sq. in. (see Figures 7 to 10)
- OA** = Open area of screen media, % (Screen Opening chart, i.e. 1/8" perf = 40%)
- Ap** = Nominal area of pipe fitting, sq. in. (see Figures 7 to 10)

STANDARD SCREEN EXAMPLE

T Strainer Size:	8"
Screen Size:	5/32" Perf
Flow Rate:	1000 GPM
Service:	Water
% Clogged:	60%

How To Calculate:

- Find the pressure drop using Figure 3.
- Reference the ratio of free area to pipe area using Figure 9.
- Using Chart # 4 above, find the correction factor based on the % clogged.
- Calculate the total pressure drop by multiplying the pressure drop from step 1 with the correction factor from step 3.

RESULTS

0.9
1.3:1 (round down to 1:1)
3.9
0.9 x 3.9 = 3.51 PSID

NON STANDARD SCREEN EXAMPLE

T Strainer Size:	8"
Screen Size:	1/8" Perf
Flow Rate:	1000 GPM
Service:	Water
% Clogged:	20%

How To Calculate:

- Find the pressure drop on page using Figure 3 with a standard screen size.
- Using the Screen Correction chart to determine the % of open area (OA) of 5/32" perf.
- See Chart # 1 to find the correction factor for 5/32" perf (round up).
- Multiply step 1 by the pressure drop from step 3.
- SINCE a non-standard screen is being used, use the formula above to calculate the Ratio free area to pipe area ($Ag = 167$, $OA = 58\%$, $Ap = 50.3$).
- Using the result from step 5, check Chart # 4 to find the correction factor.
- Multiply results from step 4 and step 6 to get the pressure drop when clogged.

RESULTS

0.9
58%
0.65
0.9 x 0.65 = 0.59 PSID
1.9:1 (round up to 2:1)
3.7
0.59 x 3.7 = 2.2 PSID

Basket Strainers

91 Series | Fabricated Basket Strainers

- Carbon or Stainless Steel
- Flanged or Butt Weld
- Sizes from 2" to 36"



SCREEN BURST PRESSURE

Basket and Duplex Basket Strainers

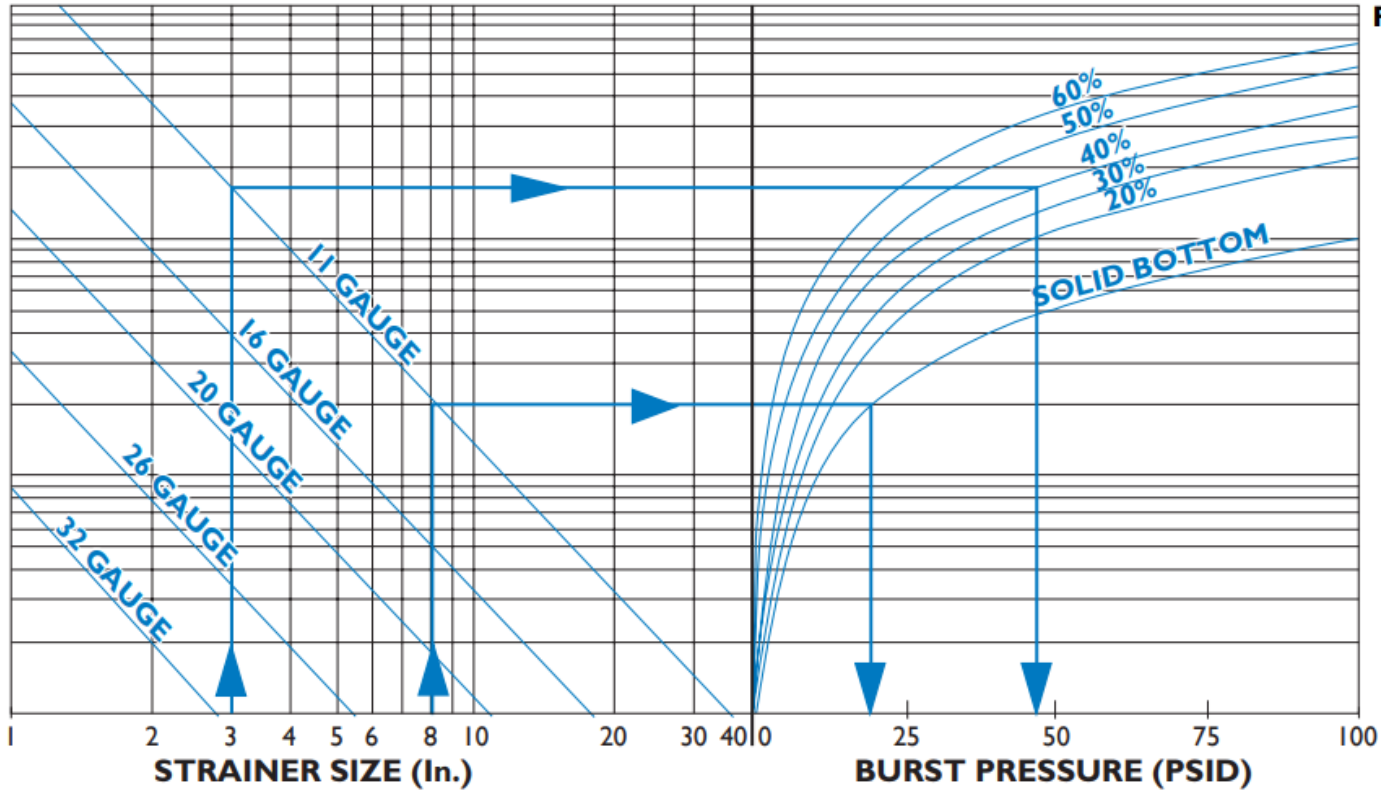

NOTES:

- The above chart is to be used for strainers manufactured from perforated plate and is based on the formula below
- The above chart is based on standard dimensions. Higher burst pressure ratings are available. Please contact factory.
- The above chart is based on a screen material of stainless steel. No safety factor is incorporated. It is the responsibility of the user to determine an acceptable safety factor.
- See the Screen Openings chart for % Open Area's of standard perforated plate.

$$t = d \sqrt{\frac{0.3P}{S}}$$

t = Thickness of perforated plate, in.
d = Basket Diameter, in.
P = Burst Pressure, psi
S = Reduced allowable stress, psi

EXAMPLE 1

Strainer Size: 8"
Basket Type: Perf w/
 11 gauge solid
 bottom
Screen Mat'l
Open Area: 20% - 60%

EXAMPLE 2

Strainer Size: 3"
Basket Type: 11 gauge w/
 11 gauge
 bottom
Screen Mat'l
Open Area: 40%

How To Calculate:

- Locate Strainer size.
- Follow vertical line to gauge thickness.
- Follow horizontal line to required perforation open area.
- Follow vertical line downward to read burst pressure.
- Burst pressure equals:
19 psid for EXAMPLE 1 and 44 psid for EXAMPLE 2

Basket Strainers

91 Series | Fabricated Basket Strainers

- Carbon or Stainless Steel
- Flanged or Butt Weld
- Sizes from 2" to 36"



SCREEN BURST PRESSURE

T Strainers

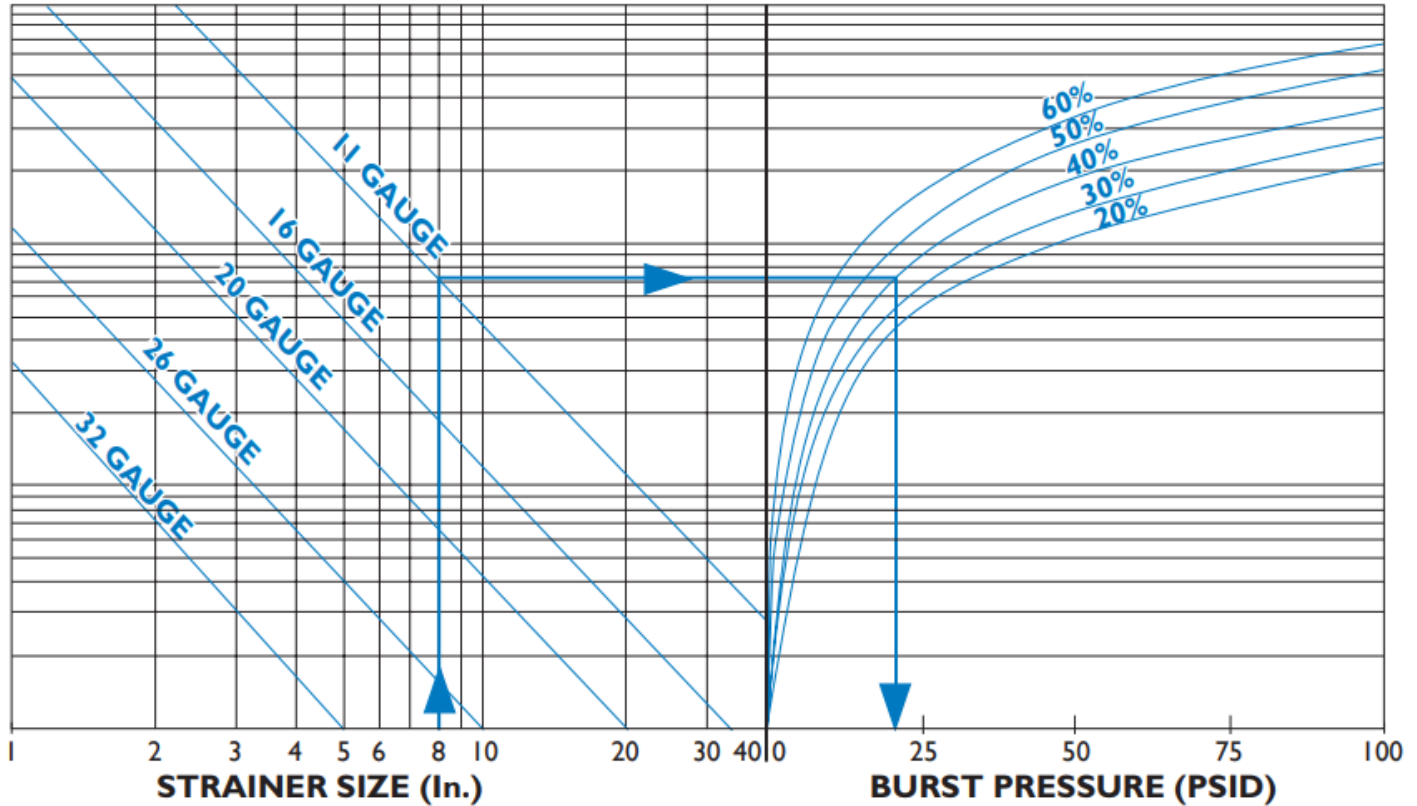

NOTES:

- The above chart is to be used for strainers manufactured from perforated plate and is based on the formula below
- The above chart is based on standard dimensions. Higher burst pressure ratings are available. Please contact factory.
- The above chart is based on a screen material of stainless steel. No safety factor is incorporated. It is the responsibility of the user to determine an acceptable safety factor.
- See the Screen Openings chart for % Open Area's of standard perforated plate.

$$t = d \sqrt{\frac{0.3P}{S}}$$

t = Thickness of perforated plate, in.
d = Basket Diameter, in.
P = Burst Pressure, psi
S = Reduced allowable stress, psi

EXAMPLE

Strainer Size:	8"
Basket Type:	11 gauge
Screen Mat'l Open Area:	40%

How To Calculate:

- Locate Strainer size.
- Follow vertical line to gauge thickness.
- Follow horizontal line to required perforation open area.
- Follow vertical line downward to read burst pressure.
- Burst pressure equals **20 psid**.

Basket Strainers

91 Series | Fabricated Basket Strainers

- Carbon or Stainless Steel
- Flanged or Butt Weld
- Sizes from 2" to 36"



SCREEN BURST PRESSURE

Y Strainers

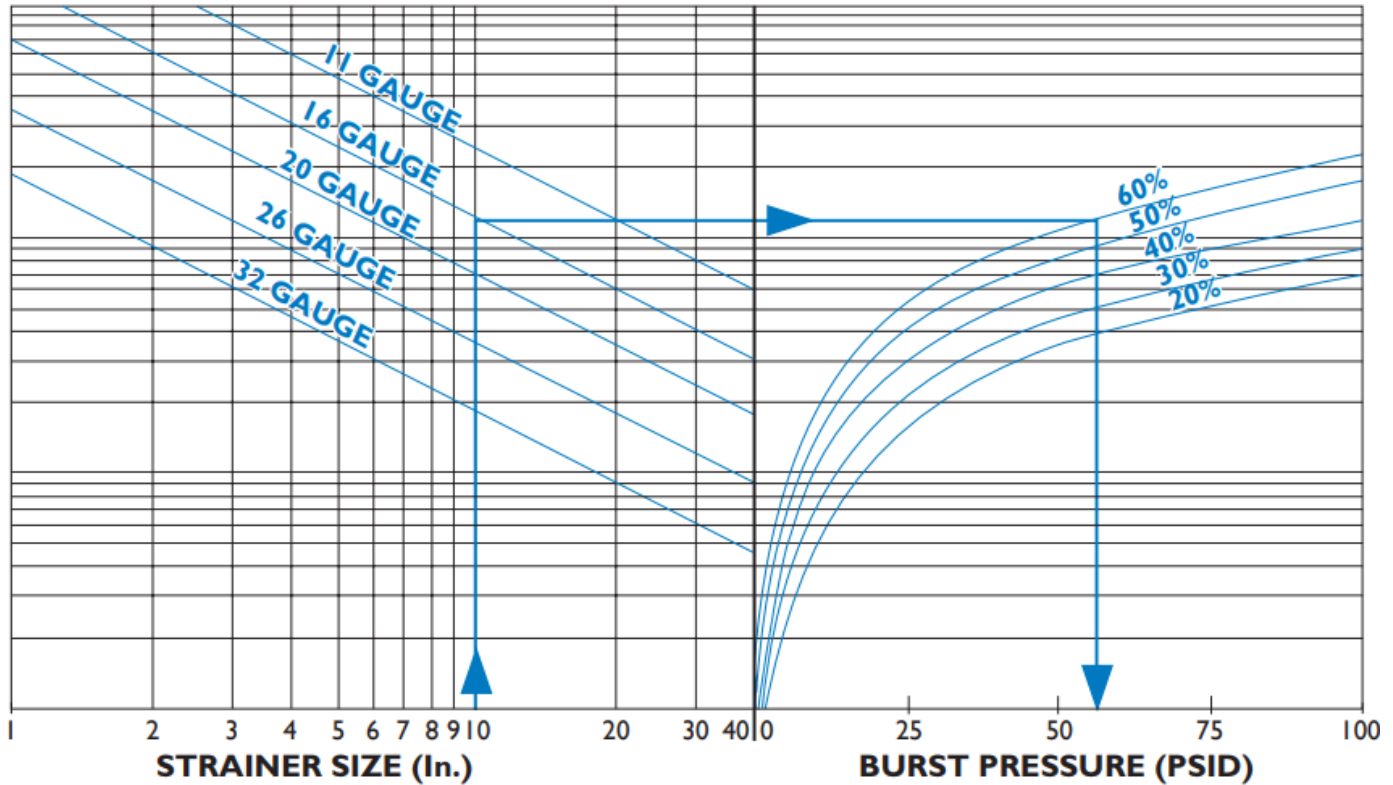

NOTES:

- The above chart is to be used for strainers manufactured from perforated plate and is based on the formula below
- The above chart is based on standard dimensions. Higher burst pressure ratings are available. Please contact factory.
- The above chart is based on a screen material of stainless steel. No safety factor is incorporated. It is the responsibility of the user to determine an acceptable safety factor.
- See the Screen Openings chart for % Open Area's of standard perforated plate.

$$P = \frac{St}{R - 0.4t}$$

P = Burst pressure, psi
S = Reduced allowable stress, psi
t = Thickness of perforated plate, in
R = Outside radius of screen, in

EXAMPLE

Strainer Size:	10"
Basket Type:	16 gauge
Screen Mat'l Open Area:	60%

How To Calculate:

- Locate Strainer size.
- Follow vertical line to gauge thickness.
- Follow horizontal line to required perforation open area.
- Follow vertical line downward to read burst pressure.
- Burst pressure equals **56 psid**.

Basket Strainers

91 Series | Fabricated Basket Strainers

- Carbon or Stainless Steel
- Flanged or Butt Weld
- Sizes from 2" to 36"



SCREEN BURST PRESSURE

Temporary Basket Strainers

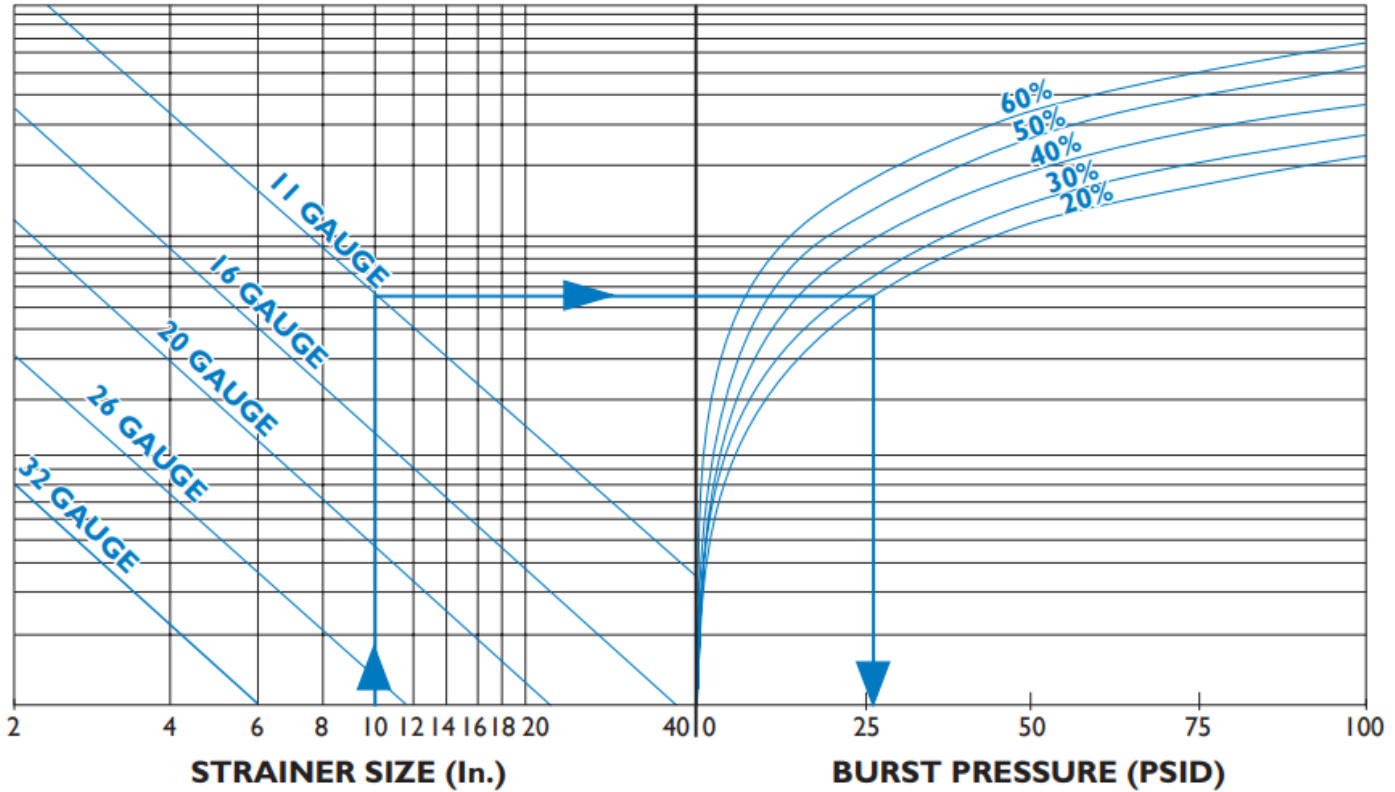

NOTES:

- The above chart is to be used for strainers manufactured from perforated plate and is based on the formula below
- The above chart is based on standard dimensions. Higher burst pressure ratings are available. Please contact factory.
- The above chart is based on a screen material of stainless steel. No safety factor is incorporated. It is the responsibility of the user to determine an acceptable safety factor.
- See the Screen Openings chart for % Open Area's of standard perforated plate.

$$t = d \sqrt{\frac{0.3P}{S}}$$

t = Thickness of perforated plate, in.
d = Dimension B (see strainer sizing), in.
P = Burst Pressure, psi
S = Reduced allowable stress, psi

EXAMPLE

Strainer Size:	10"
Basket Type:	11 gauge
Screen Mat'l Open Area:	20%

How To Calculate:

- Locate Strainer size.
- Follow vertical line to gauge thickness.
- Follow horizontal line to required perforation open area.
- Follow vertical line downward to read burst pressure.
- Burst pressure equals **27 psid**.

Basket Strainers

91 Series | Fabricated Basket Strainers

- Carbon or Stainless Steel
- Flanged or Butt Weld
- Sizes from 2" to 36"



SCREEN BURST PRESSURE

Conical Strainers

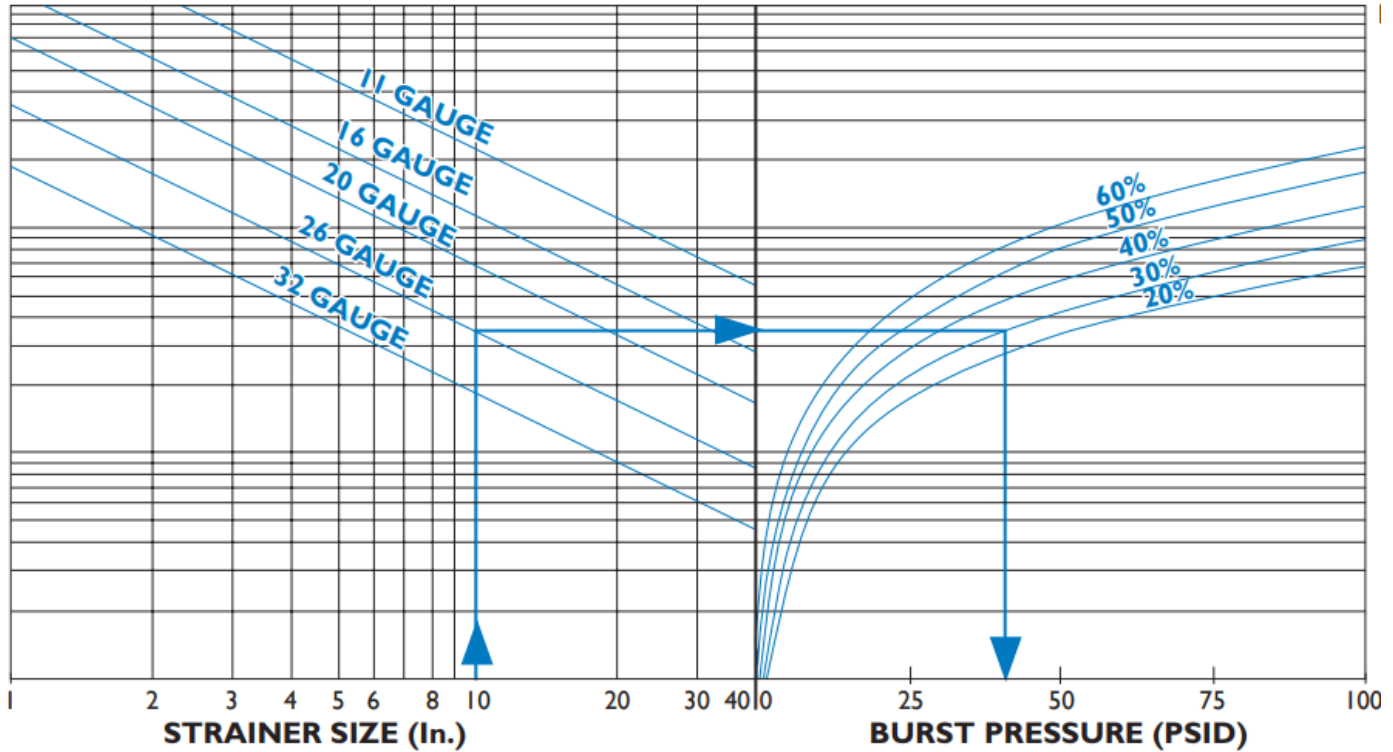

NOTES:

- The above chart is to be used for strainers manufactured from perforated plate and is based on the formula below
- The above chart is based on standard dimensions. Higher burst pressure ratings are available. Please contact factory.
- The above chart is based on a screen material of stainless steel. No safety factor is incorporated. It is the responsibility of the user to determine an acceptable safety factor.
- See the Screen Openings chart for % Open Area's of standard perforated plate.

$$P = \frac{2St \cos 15^\circ}{D + 1.2t \cos 15^\circ}$$

- t** = Thickness of perforated plate, in.
d = Dimension B (see strainer sizing), in.
P = Burst Pressure, psi
S = Reduced allowable stress, psi
 15° = 15 degree

EXAMPLE

- Strainer Size:** 10"
Basket Type: 26 gauge
Screen Mat'l Open Area: 30%

How To Calculate:

- Locate Strainer size.
- Follow vertical line to gauge thickness.
- Follow horizontal line to required perforation open area.
- Follow vertical line downward to read burst pressure.
- Burst pressure equals **41 psid**.

Basket Strainers

91 Series | Fabricated Basket Strainers

- Carbon or Stainless Steel
- Flanged or Butt Weld
- Sizes from 2" to 36"



FABRICATED STRAINER SCREEN EFFECTIVE AREAS

Basket Strainers | 2" to 24"

Figure 7

PIPE SIZE (IN)	PERF. DIAMETER (IN)	NOM. AREA OF SCH 40/STD. PIPE (IN ²)	GROSS SCREEN AREA (IN ²)	FREE AREA (IN ²)	RATIO FREE AREA TO PIPE AREA (OAR)
2	1/8"	3.36	215	86	25.6
3	1/8"	7.39	265	106	14.3
4	1/8"	12.73	265	106	8.3
5	1/8"	20.01	380	152	7.6
6	1/8"	28.89	560	224	7.8
8	1/8"	50.03	570	228	4.6
10	1/8"	78.85	910	364	4.6
12	1/8"	113.10	1300	520	4.6
14	3/16"	140.50	1600	640	4.6
16	3/16"	185.66	1830	732	3.9
18	3/16"	237.10	2290	916	3.9
20	3/16"	294.83	2800	1120	3.8
24	3/16"	429.13	4090	1636	3.8

Duplex Basket Strainers | 2" to 24"

Figure 8

PIPE SIZE (IN)	PERF. DIAMETER (IN)	NOM. AREA OF SCH 40/STD. PIPE (IN ²)	GROSS SCREEN AREA (IN ²)	FREE AREA (IN ²)	RATIO FREE AREA TO PIPE AREA (OAR)
2	1/8"	3.36	215	86	25.6
3	1/8"	7.39	265	106	14.3
4	1/8"	12.73	265	106	8.3
5	1/8"	20.01	380	152	7.6
6	1/8"	28.89	560	224	7.8
8	1/8"	50.03	570	228	4.6
10	1/8"	78.85	910	364	4.6
12	1/8"	113.10	1300	520	4.6
14	3/16"	140.50	1600	640	4.6
16	3/16"	185.66	1830	732	3.9
18	3/16"	237.10	2290	916	3.9
20	3/16"	294.83	2800	1120	3.8
24	3/16"	429.13	4090	1636	3.8

OAR = Free Screen Area / Inlet Area

Free Screen Area = Opening % x Gross Screen Area

Values shown are approximate.

Basket Strainers

91 Series | Fabricated Basket Strainers

- Carbon or Stainless Steel
- Flanged or Butt Weld
- Sizes from 2" to 36"



FABRICATED STRAINER SCREEN EFFECTIVE AREAS

T Strainers | 2" to 24"

Figure 9

PIPE SIZE (IN)	PERF. DIAMETER (IN)	NOM. AREA OF SCH 40/STD. PIPE (IN ²)	GROSS SCREEN AREA (IN ²)	FREE AREA (IN ²)	RATIO FREE AREA TO PIPE AREA (OAR)
2	1/8"	3.36	22	9	2.6
3	1/8"	7.39	40	16	2.2
4	1/8"	12.73	58	23	1.8
5	1/8"	20.01	82	33	1.6
6	1/8"	28.89	105	42	1.5
8	1/8"	50.03	167	67	1.3
10	1/8"	78.85	235	94	1.2
12	1/8"	113.10	330	132	1.2
14	3/16"	140.50	420	168	1.2
16	3/16"	185.66	510	204	1.1
18	3/16"	237.1	640	256	1.1
20	3/16"	294.83	780	312	1.1
24	3/16"	429.13	1060	424	1.0

Y Basket Strainers | 2" to 24"

Figure 10

PIPE SIZE (IN)	PERF. DIAMETER (IN)	NOM. AREA OF SCH 40/STD. PIPE (IN ²)	GROSS SCREEN AREA (IN ²)	FREE AREA (IN ²)	RATIO FREE AREA TO PIPE AREA (OAR)
2	1/8"	3.36	39	16	4.6
3	1/8"	7.39	77	31	4.2
4	1/8"	12.73	135	54	4.2
5	1/8"	20.01	160	64	3.2
6	1/8"	28.89	215	86	3.0
8	1/8"	50.03	375	150	3.0
10	1/8"	78.85	545	218	2.8
12	1/8"	113.10	785	314	2.8
14	3/16"	140.50	900	360	2.6
16	3/16"	185.66	1210	484	2.6
18	3/16"	237.1	1560	625	2.6
20	3/16"	294.83	1950	780	2.6
24	3/16"	429.13	2765	1106	2.6

OAR = Free Screen Area / Inlet Area

Free Screen Area = Opening % x Gross Screen Area

Values shown are approximate. .

Basket Strainers

91 Series | Fabricated Basket Strainers

- Carbon or Stainless Steel
- Flanged or Butt Weld
- Sizes from 2" to 36"



INSTALLATION AND MAINTENANCE INSTRUCTIONS

Strainer installation instructions

- Ensure all machined surfaces are free of defects and that the inside of the strainer is free of foreign objects.
- For horizontal and vertical pipelines, the strainer should be installed so that the blow-down drain connection is pointed downward.
- For flanged end strainers, the flange bolting should be tightened gradually in a back and forth clockwise motion. Threaded end strainers should use an appropriate sealant.
- Once installed, increase line pressure gradually and check for leakage around joints.
- If the strainer is supplied with a start-up screen, monitor pressure drop carefully.

Screen removal instructions

- Drain piping
- Vent line to relieve pressure.
- Loosen cover and open to access screen.
- Remove, clean and replace screen in original position (Note: In some instances, a high pressure water jet or steam may be required for effective cleaning)
- Inspect cover gasket for damage. If necessary, replace. (Note: If spiral wound gaskets have been used, they must be replaced and can not be used again)
- Tighten cover. The strainer is ready for line startup.

CAUTION SHOULD BE TAKEN DUE TO POSSIBLE EMISSION OF PROCESS MATERIAL FROM PIPING. ALWAYS ENSURE NO LINE PRESSURE EXISTS WHEN OPENING COVER

Maintenance instructions

For maximum efficiency, determine the length of time it takes for the pressure drop to double that in the clean condition. Once the pressure drop reaches an unacceptable value, shut down line and follow the "Screen Removal Instructions" above. A pressure gauge installed before and after the strainer in-line will indicate pressure loss due to clogging and may be used to determine when cleaning is required.

Trouble shooting guides and diagnostic techniques

- After pressurizing, inspect cover and other joints for leakage. Gasket replacement or cover tightening is necessary if leakage occurs.
- If the required filtration is not taking place, ensure the screen is installed in the correct position, that being flush to the screen seating surfaces.

WARNING

This product operates in pipelines or with equipment that carries fluids and/or gasses at elevated temperatures and pressures. Caution should be taken to make sure that this equipment is installed correctly and inspected regularly. Caution should also be taken to protect personnel from fluid or gas leakage.